

TEMPERATURE SWITCHES TSZ2H – RS485



DESCRIPTION AND APPLICATION

These temperature switches with display are designed to be used as two-state controllers (ON/OFF type control). They compare the temperature set-point with the actual temperature value and enable switching the galvanically separated (electrically insulated) contacts of a connected relay when the pre-set temperature limit is reached. Supply voltage of the switches is 7 to 36 V DC or 230 V AC (by the type). Two temperature sensing elements on the base of Pt (Pt 1000/3850) or on the base of Ni (Ni 1000/6180) can be connected to the switches. The display indicates the present value of the measuring temperature during measure process. Setting of individual parameters is executed by two control buttons.

The switch can be used in 5 different modes:

- Mode no. 1: The switch operates as a single controller which switches the first relay by the pre-set temperature interval and the second relay is activated when exceeding the pre-set critical temperature (only one sensing element is used).
- Mode no. 2: The switch operates as a single controller which switches each relay by the pre-set temperature interval (only one sensing element is used).
- Mode no. 3: The switch operates as a double controller, it means that each relay is controlled by the temperature of one sensing element.
- Mode no. 4: The switch operates as a differential controller which switches on the base of temperature difference of two sensing elements (similar to mode no. 1).
- Mode no. 5: The switch operates as a differential controller which switches on the base of temperature difference of two sensing elements (similar to mode no. 2).

The time delay of switching-off for the relay 1 within the limits 0–300 s can be set in each mode.

Measurements and setting all parameters can be done by means of the industrial bus RS485 with the protocols Modbus RTU (standardly), Adam and Arion that must be specified in an order. With a simple converter RS485/RS232 the switch can be connected to the PC-serial port to make various settings. Please contact ATAL for further details on this software. The switches are developed for DIN-rail mounting. The temperature range of the switch applications depends on the type of temperature sensing element applied (for example for the sensor in the TG8 case the range is -50 to 200 °C). Maximum operating temperature range of the switch is -50 to 250 °C.

The switches are intended to operate in a chemically non-aggressive environment.



DECLARATION, CERTIFICATES, CALIBRATION

EC Declaration of Conformity – in accordance with Act No. 22/1997 Coll. as amended for temperature switches.

Calibration – we perform standard calibration of resistance temperature sensors in accordance with EN ISO/IEC 17025 in the temperature range -70 to 600 °C.

SPECIFICATIONS

Switch type	TSZ2H-24 – RS485	TSZ2H-230 – RS485
Output	2 relays	
Type of sensing element	Pt 1000/3850 or Ni 1000/6180	
Maximum temperature operating range	-50 to 250 °C	
Power supply	7–36 V DC, V AC	230 V AC
Maximum switched voltage	250 V AC / 6 A	
Maximum error of the switch*	± (0.2 % from the value + 2 dig)	
Resolution	0.1 °C	
Setting range	-50 to 250 °C, step 0.1 °C	
Display	4 digits – red LED, high of the digits 10 mm	
Brightness of the display setting	4 levels	
Updating of the display	< 0.2 s	
Type of terminal board	terminal board ARK210, wire cross section 0.35 to 1.5 mm ²	
Material of the case	ABS, self-extinguishing, meeting the UL94-V0 standard	
Dimensions of the case	86 x 67 x 65 mm	
Ingress protection	IP 20 according to EN 60 529	
Operating conditions	ambient temperature: -5 to 60 °C	
	relative humidity: max 85 % (at the ambient temperature 25 °C)	
	atmospheric pressure: 87 to 107 kPa	
Weight	0.15 kg (without sensing element)	0.25 kg without sensing element

*error of the sensing element is not incorporated

TEMPERATURE SWITCHES TSZ2H – RS485

COMMUNICATON PROPERTIES

communication via RS 485, maximum segment length is 1200 m, asynchronous transfer

 transfer speeds 1200, 2400, 4800 Bd
 32 modules / 1 serial port
 protocol consistent with ADAM modules

 transfer speeds 1200, 2400, 4800 Bd
 32 modules / 1 serial port
 protocol ARION

 transfer speeds 1200, 2400, 4800 Bd
 32 modules / 1 serial port
 protocol ModBus 1 stop bit, without parity

WIRING DIAGRAM

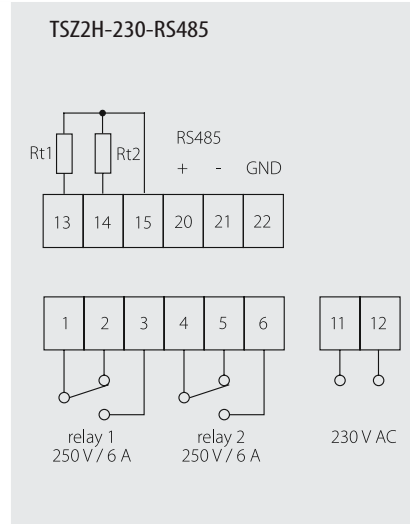
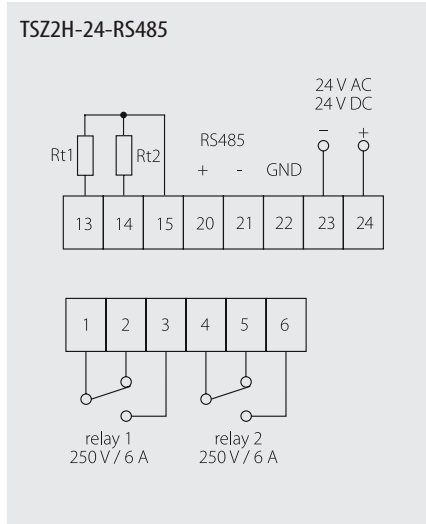

DIMENSIONAL DRAFT

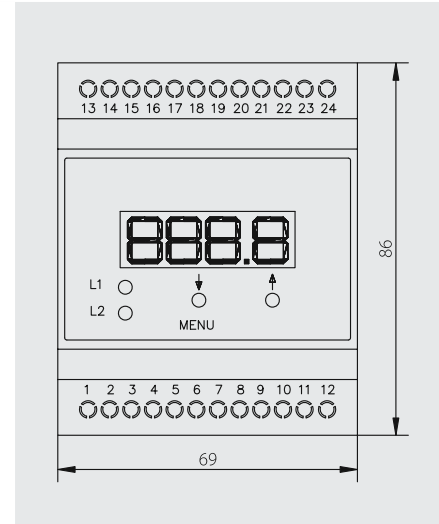

SWITCH INSTALLATION AND SERVICING

An integral part of the switch is a clamp enabling to mount the switch on a DIN-rail. After mounting the unit the relevant supply lead-in cables (terminals 23, 24 – 24 V AC/DC, terminals 11, 12 – 230 V AC), the temperature sensors (terminals 13, 15 – sensing element 1; terminals 14, 15 – sensing element 2), the cable for the relay output signal (1, 2, 3 – relay 1; 4, 5, 6 - relay 2) and RS 485 bus (terminals 20, 21, 22) are connected to the terminals according to the wiring diagram. The recommended wire cross-section is 0.35 to 1.5 mm².

In case the lead-in cable is laid in the vicinity of high voltage conductors or those supplying equipment creating disturbing electromagnetic field (e.g. inductive load equipment), a shielded cable should be used. The shielding of the lead-in cable of the temperature sensor is connected to the terminal no. 3.

CUSTOMER SPECIFIC MODIFICATIONS

REGARDING TO SENSORS MANUFACTURED IN A STANDARD VERSION THE FOLLOWING PARAMETERS CAN BE MODIFIED:

- change of the communications protocol - Adam, Arion